

CIANA-44 ECO ANTIGLARE

CNA 44 ECO AG

Mono IP20 CE

YYZ Ciana ECO series is a surface/ suspension mounted luminaire with extruded aluminium housing, with PMMA diffuser as optic. Options of Direct/ Indirect component makes it Ideal for varied commercial spaces, particularly for office lighting applications.

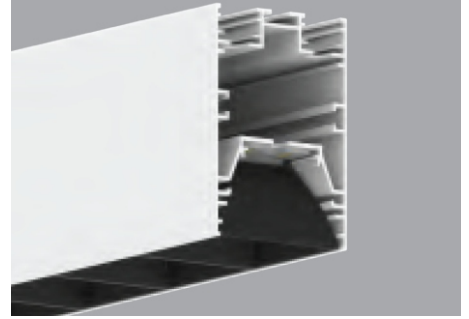

FEATURES

HOUSING	Extruded aluminium
FINISH	White, Grey, Black
BEAM ANGLE	80°
MOUNTING	Pendant, Surface, Recessed mounting
OPTIC	PMMA Milky, PMMA Black
DIMENSIONS	240x44x64mm
OPERATION TEMP	-20° C - +50° C
LAMP LIFE	50,000 hrs
CONTROL	On/Off, Dali, 1-10V
LUMEN	70lm/W

- CREE/SAMSUNG LED Quality
- 220-240V AC Working Voltage
- 24W/960mm Rated power

ELECTRICAL DATA

RATED POWER	24W/960mm
COLORS	3000K, 4000K, 5000K
CRI	90
LUMEN	85 lm/W

DIMENSION

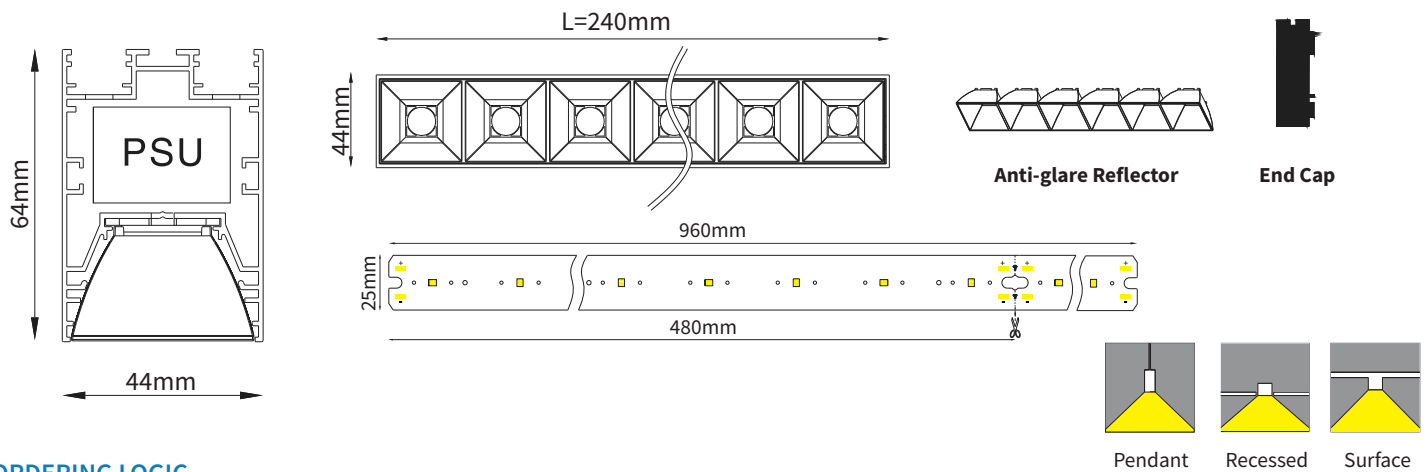

ORDERING LOGIC

PRODUCT	WATTAGE	COLOR TEMPERATURE	DRIVER	FINISH	MOUNTING	ACCESSORIES	
CNA 44 ECO AG	24 - 24W/960mm	(CT30)	3000K	SW - ON-OFF	WH - White	PE - Pendant	AGR - Anti-Glare Reflector
		(CT40)	4000K	AN - 0-10V	BK - Black	RE - Recessed	
		(CT50)	5000K	DA - DALI	GR - Grey	SU - Surface	

Sample: CNA 44 ECO AG - 24 - CT27 - SW - WH - PE - AGR