

# SURFACEMOUNTED DOWN LIGHT SERIES

## SMDLCH 4610

**Mono** IP20 **CE**

YYZ SMDLCH is surface mounted LED downlight is with symmetric light distribution to achieve an effective task, accent or ambient lighting. These downlights are also suitable for all commercial lighting applications as well as public indoor space where there is limited space in ceiling. It is available in white and black finishes.



### FEATURES

MATERIAL	Aluminum
TRIM FINISH	White, Black
RATED POWER	2x8W
WORKING VOLTAGE	AC 230V-50Hz
RADIANCE ANGLE	15°, 24°, 38°, 50°
MOUNTING	Surface mounted
CONNECTION	Indoor rated connections
LAMP LIFE	50,000 Hrs
DIMENSION	156 x 80 x 100mm
OPERATING TEMP	-20° C - +50° C
CONTROL	On/Off

CREE LED Quality

AC 230V Working Voltage

2x8W Rated power

### ELECTRICAL DATA

POWER CONSUMPTION	2x8W
SUPPLY VOLTAGE	AC 230V
COLORS	2700K, 3000K, 4000K
CRI	92
LUMEN	2x630 lm

### DIMENSIONS

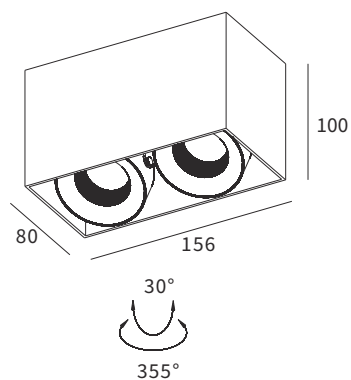

### ORDERING LOGIC

PRODUCT	WATTAGE	COLOR TEMPERATURE		CONTROL	VOLTAGE	BEAM ANGLE	FINISH	CUSTOM
SMDLCH 4610	16 - 2x8W	(CT27)	2700K	ON/OFF	AC - AC230V	15 - 15°	WH - White	xx
		(CT30)	3000K			24 - 24°	BK - Black	
		(CT40)	4000K			38 - 38°		
						50 - 50°		

Sample: SMDLCH 4610 - 16 - CT27 - ON/OFF - AC - 15 - WH - XX