

# SML-25-SPOT LIGHT-25W



YYZ SML series spot light Mono is high brightness and easy installation for Landscape solution. Available in different wattage. IP65, UV-resistant. Aluminum black body finish.

## FEATURES

LED QUANTITY	1Nos
FINISH	BLACK /GREY
WORKING VOLTAGE	220-240 VAC
RATED POWER	25W
RADIANCE ANGLE	13°/23°/38°
LAMP LIFE	50000 HRS
MOUNTING	GROUND / SPIKE / TREE MOUNT BRACKET
CONNECTION	OUTDOOR RATED CONNECTIONS
DIMENSIONS	Ø95 x 238 x 457 mm
OPERATION TEMP	-20° C - +50° C
STORAGE TEMP	-20° C - +60° C
CABLE	H05RN 1 Mtr PIG TAIL
BODY	ALUMINUM 6063



**1 LED CREE**  
LED Quality

**V 220-240 VOLTS**  
Working Voltage

**W 25W**  
Rated power

## ELECTRICAL DATA

POWER CONSUMPTION	25W
SUPPLY VOLTAGE	220-240 VAC INTEGRAL DRIVER
CRI	80+
LEDS	CREE COB
LUMENS	2107lm @ 3000K



## DRAWING

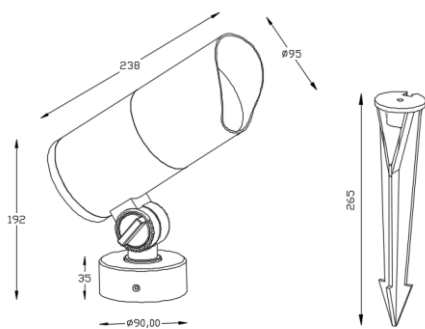

## ORDERING LOGIC

PRODUCT	CONTROL	OPTIC	COLOR TEMPARTURE	VOLTAGE	MOUNTING	CONNECTION	FINISH	ACCESSORIES	CUSTOM
SML 25	ND- Non Dimmable (Dimming options discuss with factory)	13 - 13° (CT27) 23 - 23° (CT30) 38 - 38° (CTXX)	2700K 3000K Custom	220-240 VAC	SP - Spike SM - Surface Mount TM - Tree Mount	PT - Pig Tail	GR - Grey BK - Black XX - Custom	HCL - Honey Comb Louver	XX - XXX

Sample: SML 25 - ND - 13 - CT27 - 220-240 - SP - PT - GR - HCL - XX